



P817-PS-24X24
24 [610] Wide Perforated Grate

Dimensional Data (inches and [mm]) are Subject to Manufacturing Tolerances and Change Without Notice

[Back to Index](#)

Please Check ✓	Item No.	Part Number	Item I.D.
	9	61029	P817-PS-24X24

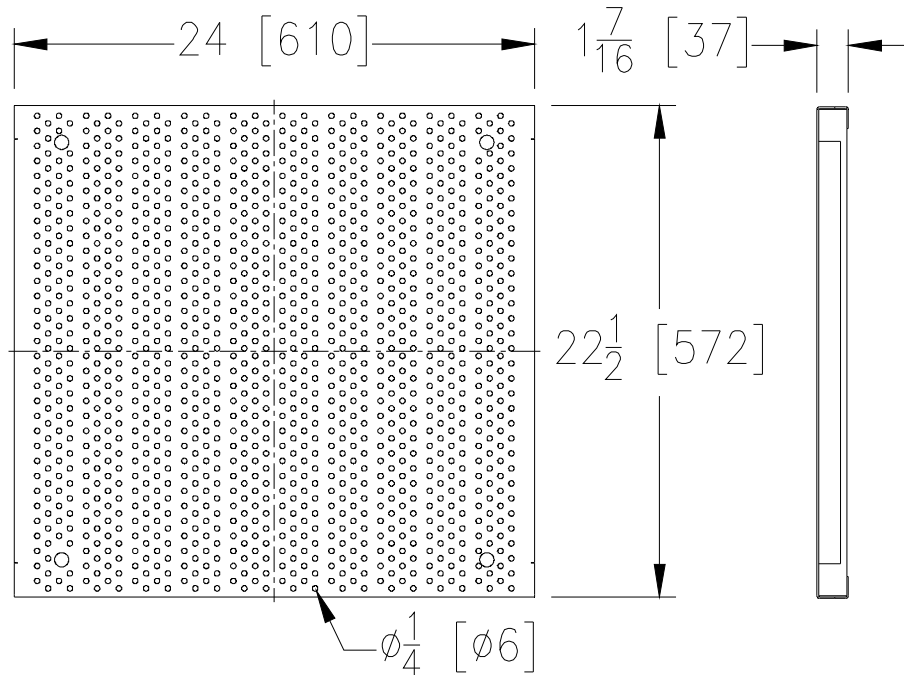

PS GRATE ENGINEERING SPECIFICATION: The Zurn P817-PS-24X24 Perforated Grate, Stainless Steel, 24 inches wide by 22-1/2 inches long, weighing 48 lbs. The grate has an open area of 62.5 square inches, DIN Rating of A and ANSI Rating of Light-Duty.

PS - Perforated Grate	
Material:	Stainless Steel
DIN Rating:	Class A
Weight:	48 lbs
Open Area:	62.5 in ²
ANSI Rating:	Light-Duty
Application:	Decorative Heel-Proof
Slot Width/Hole Size:	1/4
ADA:	Yes
H-20:	No
FAA:	No